



ETA-Danmark A/S
Göteborg Plads 1
DK-2150 Nordhavn
Tel. +45 72 24 59 00
Fax +45 72 24 59 04
Internet www.etadanmark.dk

Authorised and notified according
to Article 29 of the Regulation (EU)
No 305/2011 of the European
Parliament and of the Council of 9
March 2011

MEMBER OF EOTA



European Technical Assessment ETA-19/0626 of 2019/09/26

I General Part

Technical Assessment Body issuing the ETA and designated according to Article 29 of the Regulation (EU) No 305/2011: ETA-Danmark A/S

Trade name of the construction product:

POLY-GPG®/ POLY-GPG® PLUS Injection System

Product family to which the above construction product belongs:

Bonded injection type anchor for use in non-cracked concrete: sizes M8 to M24, rebar Ø8 to Ø25 mm

Manufacturer:

Simpson Strong-Tie®
Rue du Camp
Z.A.C. des Quatre Chemins
F-85400 Sainte Gemme La Plaine
Tel. +33 2 51 28 44 00
Fax +33 2 51 28 44 01
Internet www.simpson.fr

Manufacturing plant:

Simpson Strong-Tie®
Manufacturing Facilities

This European Technical Assessment contains:

20 pages including 15 annexes which form an integral part of the document

This European Technical Assessment is issued in accordance with Regulation (EU) No 305/2011, on the basis of:

EOTA EAD 330499-01-0601, "Bonded fasteners for use in concrete"

This version replaces:

Translations of this European Technical Assessment in other languages shall fully correspond to the original issued document and should be identified as such.

Communication of this European Technical Assessment, including transmission by electronic means, shall be in full (except the confidential Annexes referred to above). However, partial reproduction may be made, with the written consent of the issuing Technical Assessment Body. Any partial reproduction has to be identified as such.

II SPECIFIC PART OF THE EUROPEAN TECHNICAL ASSESSMENT

1 Technical description of product and intended use

Technical description of the product

The POLY-GPG®/ POLY-GPG® PLUS is a bonded anchor (injection type) for concrete consisting of a cartridge with POLY-GPG®/ POLY-GPG® PLUS injection mortar and a steel element. The steel element consists of a commercial threaded rod with washer and hexagon nut in the range of M8 to M24 or a reinforcing bar in the range of diameter Ø8 to Ø25 mm.

The product specification is given in annex A.

The steel element is placed into a drilled hole filled with injection mortar and is anchored via the bond between metal part, injection mortar and concrete.

The characteristic material values, dimensions and tolerances of the anchors not indicated in Annexes shall correspond to the respective values laid down in the technical documentation¹ of this European Technical Assessment.

2 Specification of the intended use in accordance with the applicable EAD

The performances given in Section 3 are only valid if the anchor is used in compliance with the specifications and conditions given in Annex B.

The provisions made in this European Technical Assessment are based on an assumed intended working life of the anchor of 50 years.

The indications given on the working life cannot be interpreted as a guarantee given by the producer or Assessment Body, but are to be regarded only as a means for choosing the right products in relation to the expected economically reasonable working life of the works.

¹ The technical documentation of this European Technical Assessment is deposited at ETA-Danmark and, as far as relevant for the tasks of the Notified bodies involved in the attestation of conformity procedure, is handed over to the notified bodies.

3 Performance of the product and references to the methods used for its assessment

3.1 Characteristics of product

Mechanical resistance and stability (BWR 1):

The essential characteristics are detailed in the Annex C.

Safety in case of fire (BWR 2):

The essential characteristics are detailed in the Annex C.

Hygiene, health and the environment (BWR3):

No performance assessed

Safety in use (BWR4):

For basic requirement Safety in use the same criteria are valid for Basic Requirement Mechanical resistance and stability (BWR1).

Sustainable use of natural resources (BWR7)

No performance assessed

Other Basic Requirements are not relevant.

3.2 Methods of assessment

The assessment of fitness of the anchor for the intended use in relation to the requirements for mechanical resistance and stability and safety in use in the sense of the Basic Requirements 1 and 4 has been made in accordance with EOTA EAD 330499-01-0601, “Bonded fasteners for use in concrete” option 7.

4 Assessment and verification of constancy of performance (AVCP)

4.1 AVCP system

According to the decision 96/582/EC of the European Commission, the system(s) of assessment and verification of constancy of performance (see Annex V to Regulation (EU) No 305/2011) is 1.

5 Technical details necessary for the implementation of the AVCP system, as foreseen in the applicable EAD

Technical details necessary for the implementation of the AVCP system are laid down in the control plan deposited at ETA-Danmark prior to CE marking.

Issued in Copenhagen on 2019-09-26 by



Thomas Bruun
Managing Director, ETA-Danmark

Cartridge: POLY-GPG®/ POLY-GPG® PLUS

- A) Foil Bag Cartridge 165ml, 300ml.**
- B) Coaxial Cartridge 380ml / 400 ml / 410 ml / 420ml**
- C) Side by Side Cartridge 345ml, 825ml**

Cartridge Print POLY-GPG®/ POLY-GPG® PLUS

Including - Installation procedure, Production Batch code, Expiry Date, Storage conditions, Health & Safety warning, Gel & Cure time according to temperatures.

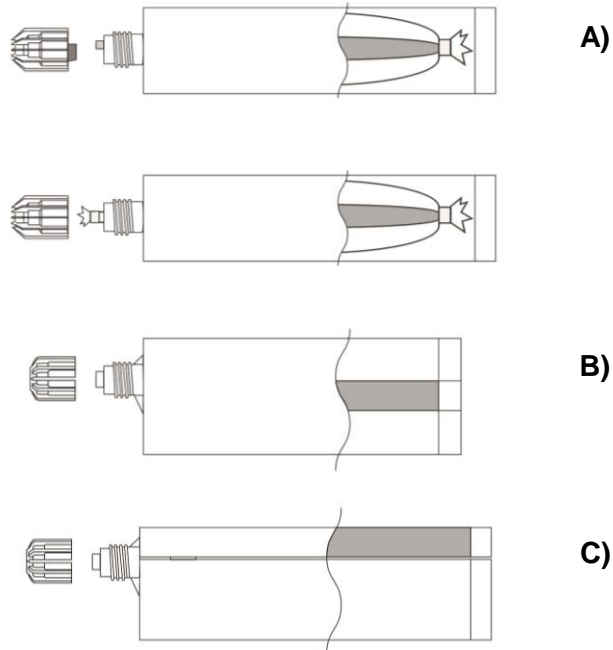

Marking:

POLY-GPG®/ POLY-GPG® PLUS

Batch code, either expiry date or manufacturing date with shelf life

Mixer with hanger

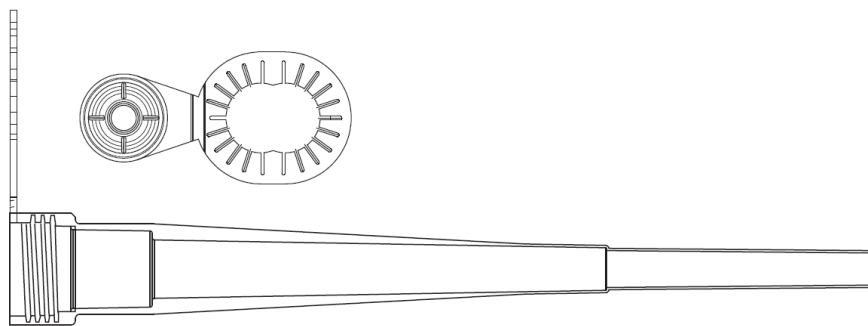

Mixer

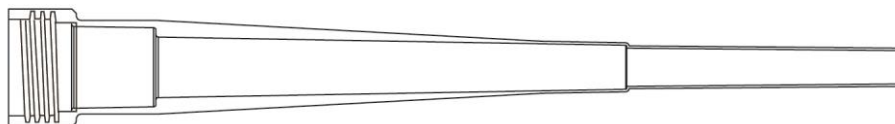

POLY-GPG®/ POLY-GPG® PLUS

Product and intended use

Annex A1
of European
Technical Assessment
ETA-19/0626

Anchor rod and rebar

Threaded Steel Stud, Nut and Washer
 Sizes M8, M10, M12, M16, M20, M24

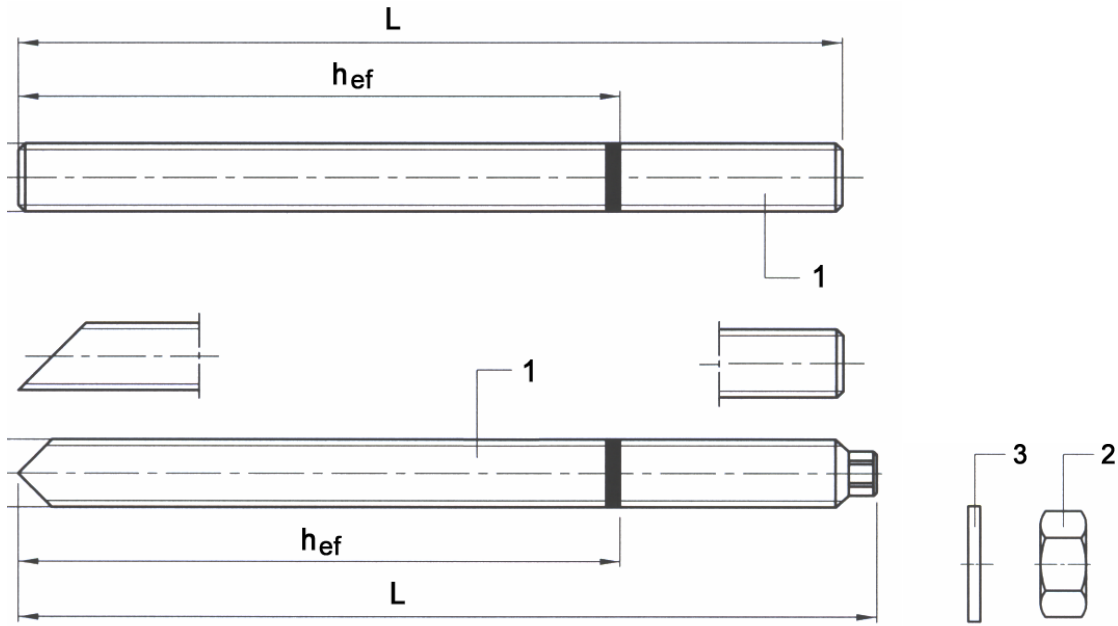

Rebar

Diameter \varnothing 8mm, \varnothing 10mm, \varnothing 12mm, \varnothing 14mm, \varnothing 16mm, \varnothing 20mm, \varnothing 25mm,



POLY-GPG®/ POLY-GPG® PLUS

Threaded rod types and rebar's dimensions

Annex A2

of European
 Technical Assessment
 ETA-19/0626

Installed Anchor and Intended Use**Table A1: Installation details for anchor rods**

Anchor size			M8	M10	M12	M16	M20	M24
Diameter of element	d	[mm]	8	10	12	16	20	24
Range of effective embedment depth h_{ef} and bore hole depth h_o	min	[mm]	60	60	70	80	90	100
	max	[mm]	96	120	144	192	240	288
Effective embedment depth	h_{ef}	[mm]	80	90	110	125	170	210
Nominal diameter of drill bit	d_o	[mm]	10	12	14	18	24	28
Diameter of clearance hole in the fixture	d_f	[mm]	9	12	14	18	22	26
Maximum torque moment	T_{max}	[Nm]	10	12	20	40	70	90
Minimum thickness of concrete member	h_{min}	[mm]	$h_{ef} + 30\text{mm}$ $\geq 100\text{mm}$			$h_{ef} + 2d_o$		
Minimum spacing	s_{min}	[mm]	40	50	60	80	100	120
Minimum edge distance	c_{min}	[mm]	40	50	60	80	100	120

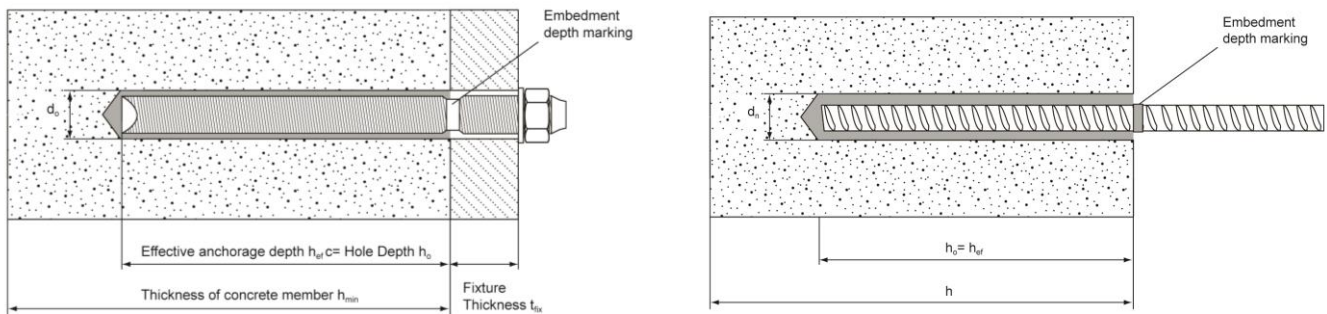
**Table A2: Installation details for rebar**

Rebar size (mm)			$\phi 8$	$\phi 10$	$\phi 12$	$\phi 14$	$\phi 16$	$\phi 20$	$\phi 25$
Diameter of element	d	[mm]	8	10	12	14	16	20	25
Range of effective embedment depth h_{ef} and bore hole depth h_o	min	[mm]	60	60	70	75	80	90	100
	max	[mm]	96	120	144	168	192	240	288
Nominal diameter of drill bit	d_o	[mm]	12	14	16	18	20	25	30
Minimum thickness of concrete member	h_{min}	[mm]	$h_{ef} + 30\text{mm}$ $\geq 100\text{mm}$			$h_{ef} + 2d_o$			
Minimum spacing	s_{min}	[mm]	40	50	60	70	80	100	120
Minimum edge distance	c_{min}	[mm]	40	50	60	70	80	100	120

POLY-GPG®/ POLY-GPG® PLUS

Installation details for threaded studs and rebar

Annex A3of European
Technical Assessment
ETA-19/0626

Table A3: Threaded rod and rebar materials

Designation	Material
Threaded rods made of zinc coated steel	
Threaded rod M8 – M24	Strength class 4.6 to 12.9 EN ISO 898-1 Steel galvanized $\geq 5\mu\text{m}$ EN ISO 4042 Hot dipped galvanized $\geq 45\mu\text{m}$ EN ISO 10684
Washer ISO 7089	Steel galvanized EN ISO 4042; hot dipped galvanized EN ISO 10684
Nut EN ISO 4032	Strength class 8 EN ISO 898-2 Steel galvanized $\geq 5\mu\text{m}$ EN ISO 4042 Hot dipped galvanized $\geq 45\mu\text{m}$ EN ISO 10684
Threaded rods made of stainless steel	
Threaded rod M8 – M24	Strength class 50, 70 or 80 EN ISO 3506; Stainless steel 1.4401; 1.4404; 1.4578; 1.4571; 1.4439; 1.4362 – EN 10088
Washer ISO 7089	Stainless steel 1.4401; 1.4404; 1.4578; 1.4571; 1.4439; 1.4362 – EN 10088
Nut EN ISO 4032	Strength class 70 and 80 EN ISO 3506-1; Stainless steel 1.4401; 1.4404; 1.4578; 1.4571; 1.4439; 1.4362 – EN 10088
Threaded rods made of high corrosion resistant steel	
Threaded rod M8 – M24	Strength class 70 or 80 $R_m = 800 \text{ N/mm}^2$; $R_{p0,2} = 640 \text{ N/mm}^2$ High corrosion resistant steel 1.4529, 1.4565 EN 10088
Washer ISO 7089	High corrosion resistant steel 1.4529, 1.4565 EN 10088
Nut EN ISO 4032	Strength class 70 EN ISO 3506-2; High corrosion resistant steel 1.4529, 1.4565 EN 10088
Rebars	
Rebars $\phi 8$ to $\phi 25$	class B and C of characteristic yield strength f_{yk} from 400 MPa to 600 MPa

POLY-GPG®/ POLY-GPG® PLUS

Materials

Annex A4
of European
Technical Assessment
ETA-19/0626

Use:

The anchors are intended to be used for anchorages for which requirements for mechanical resistance and stability and safety in use in the sense of the Basic Requirements 1 and 4 of Regulation 305/2011 (EU) shall be fulfilled and failure of anchorages made with these products would compromise the stability of the works, cause risk to human life and/or lead to considerable economic consequences.

Anchors subject to:

- Static and quasi-static loads: M8 to M24, Rebar $\varnothing 8$ to $\varnothing 25$

Base materials:

- Reinforced or unreinforced normal weight concrete of strength class C20/25 at minimum to C50/60 at maximum according to EN 206-1.
- Non-cracked concrete: sizes from M8 to M24 and rebar $\varnothing 8$ mm to $\varnothing 25$ mm

Temperature range:

The anchors may be used in the following temperature range:

- a) T: - 40 °C to + 40°C (max short term temperature + 40 °C and max long term temperature + 24 °C).

Use conditions (Environmental conditions):

Elements made of galvanized steel and stainless steel may be used in structures subject to the following conditions:

- Structures subject to dry internal conditions (zinc coated steel, stainless steel A2 resp. A4 or high corrosion resistant steel).
- Structures subject to external atmospheric exposure (including industrial and marine environment) and to permanently damp internal condition, if no particular aggressive conditions exist (stainless steel A4 or high corrosion resistant steel).
- Structures subject to external atmospheric exposure and to permanently damp internal condition, if other particular aggressive conditions exist (high corrosion resistant steel).
- Note: Particular aggressive conditions are e.g. permanent, alternating immersion in seawater or the splash zone of seawater, chloride atmosphere of indoor swimming pools or atmosphere with extreme chemical pollution (e.g. in desulphurization plants or road tunnels where de-icing materials are used).

Installation:

The anchors may be installed in:

- Dry or wet concrete (use category 1)
- Flooded holes with the exception of seawater (use category 2)
- All the diameters may be used overhead
- The anchor is suitable for hammer drilled holes

Proposed design methods:





- Static and quasi-static load: EN 1992-4

POLY-GPG®/ POLY-GPG® PLUS

Intended use - Specification

Annex B1
of European
Technical Assessment
ETA-19/0626

Table B1: Installation data

Threaded rod and rebar	Size	Nominal drill bit diameter d_o (mm)	Steel Brush d_b (mm)	Cleaning methods	
				Manual cleaning (MAC)	Compressed air cleaning (CAC)
Studs 	M8	10	12 mm	Yes ... $h_{ef} \leq 80$ mm	Yes
	M10	12	14 mm	Yes ... $h_{ef} \leq 100$ mm	
	M12	14	16 mm	Yes ... $h_{ef} \leq 120$ mm	
	M16	18	20 mm	Yes ... $h_{ef} \leq 160$ mm	
	M 20	24	26 mm	Yes ... $h_{ef} \leq 200$ mm	
	M 24	28	30 mm	Yes ... $h_{ef} \leq 240$ mm	
Rebar 	ϕ 8 mm	12	14 mm	Yes ... $h_{ef} \leq 80$ mm	Yes
	ϕ 10 mm	14	16 mm	Yes ... $h_{ef} \leq 100$ mm	
	ϕ 12 mm	16	18 mm	Yes ... $h_{ef} \leq 120$ mm	
	ϕ 14 mm	18	20 mm	Yes ... $h_{ef} \leq 140$ mm	
	ϕ 16 mm	20	22 mm	Yes ... $h_{ef} \leq 160$ mm	
	ϕ 20 mm	25	28 mm	Yes ... $h_{ef} \leq 200$ mm	
	ϕ 25 mm	30	34 mm	Yes ... $h_{ef} \leq 240$ mm	

Manual Cleaning (MAC):

Hand pump recommended for
Blowing out bore holes with diameters
 $d_o \leq 24$ mm and bore holes depth $h_o \leq 10d$

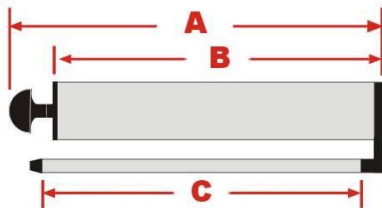

190mm (240x190x300mm) -(A) : 240mm (overall) -(B) : 190mm (Body) -(C) : 300mm (Tube)	280mm (330x280x300mm) -(A) : 330mm (overall) -(B) : 280mm (Body) -(C) : 300mm (Tube)	400mm (420x370x350mm) -(A) : 420mm (overall) -(B) : 370mm (Body) -(C) : 350mm (Tube)
---	---	---

Compressed air cleaning (CAC):

Recommended air nozzle with an
Orifice opening of minimum
3,5mm in diameter.

**POLY-GPG®/ POLY-GPG® PLUS**





Intended use – data

Annex B2
of European
Technical Assessment
ETA-19/0626

Table B2: Minimum curing time

Minimum base material temperature C°	Gel time (working time) In dry/wet concrete	Curing time in dry concrete	Curing time in wet concrete
0°C ≤ T _{base material} < 10°C	20 min	90 min	180 min
10°C ≤ T _{base material} < 20°C	9 min	60 min	120 min
20°C ≤ T _{base material} < 30°C	5 min	30 min	60 min
30°C ≤ T _{base material} ≤ 40°C	3 min	20 min	40 min

The temperature of the bond material must be ≥ 20°C

Resin injection pump details		
Image	Size Cartridge / Code	Type
	165 / 300ml 165 / 300 ml 10:1	Manual
	345 / 380 / 400 / 410 / 420ml 420 ml 10:1 345 ml 10:1	Manual
	165 / 300 / 345 / 380 / 400 / 410 / 420ml 165 / 300 ml 345ml 380 / 400 / 410 / 420 ml 7.4v Tool	Battery
	380 / 400 / 410 / 420 / 825ml 380 / 400 / 410 / 420 ml 825ml	Pneumatic

POLY-GPG®/ POLY-GPG® PLUS

Intended use – data

Annex B3
of European
Technical Assessment
ETA-19/0626

Table B3 - parameters: drilling, hole cleaning and installation

Bore hole drilling		
		Drill hole in the substrate to the required embedment depth using the appropriately sized carbide drill bit.
Bore hole cleaning Just before setting an anchor, the bore hole must be free of dust and debris.		
a) Manual air cleaning (MAC) for all bore hole diameters $d_o \leq 24\text{mm}$ and bore hole depth $h_o \leq 10d$		
	X 4	The manual pump shall be used for blowing out bore holes up to diameters $d_o \leq 24\text{mm}$ and embedment depths up to $h_{ef} \leq 10d$. Blow out at least 4 times from the back of the bore hole, using an extension if needed.
	X 4	Brush 4 times with the specified brush size (see Table B1) by inserting the steel brush to the back of the hole (if needed with an extension) in a twisting motion and removing it.
	X 4	Blow out again with manual pump at least 4 times.
b) Compressed air cleaning (CAC) for all bore hole diameters d_o and all bore hole depths		
	X 2	Blow 2 times from the back of the hole (if needed with a nozzle extension) over the whole length with oil-free compressed air (min. 6 bar at $6\text{ m}^3/\text{h}$).
	X 2	Brush 2 times with the specified brush size (see Table B1) by inserting the steel brush to the back of the hole (if needed with an extension) in a twisting motion and removing it.
	X 2	Blow out again with compressed air at least 2 times.
POLY-GPG®/ POLY-GPG® PLUS		Annex B3 of European Technical Assessment ETA-19/0626
Procedure (1)		

Table B4 - parameters: drilling, hole cleaning and installation

	<p>Remove the threaded cap from the cartridge. Cut open the foil bag if necessary.</p>
	<p>Tightly attach the mixing nozzle. Do not modify the mixer in any way. Make sure the mixing element is inside the mixer. Use only the supplied mixer.</p>
	<p>Insert the cartridge into the dispenser gun.</p>
	<p>Discard the initial trigger pulls of adhesive. Depending on the size of the cartridge, an initial amount of adhesive mix must be discarded. Discard quantities are 10 cm for all cartridges</p>
	<p>Inject the adhesive starting at the back of the hole, slowly withdrawing the mixer with each trigger pull. Fill holes approximately 2/3 full, to ensure that the annular gap between the anchor and the concrete is completely filled with adhesive along the embedment depth.</p>
	<p>Before use, verify that the threaded rod is dry and free of contaminants. Install the threaded rod to the required embedment depth during the open gel time t_{gel} has elapsed. The working time t_{gel} is given in Table B2.</p>
	<p>The anchor can be loaded after the required curing time t_{cure} (see Table B2). The applied torque shall not exceed the values T_{max} given in Table A1.</p>

POLY-GPG®/ POLY-GPG® PLUS

Procedure (2)

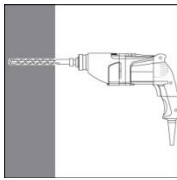
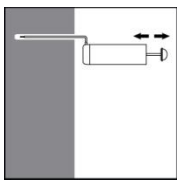
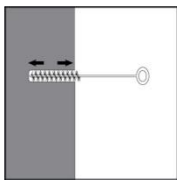
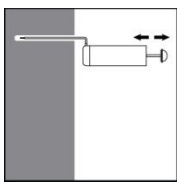
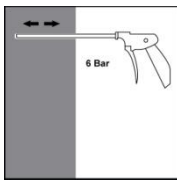
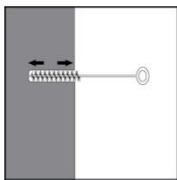
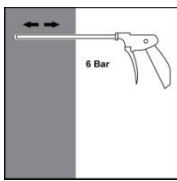
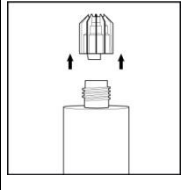
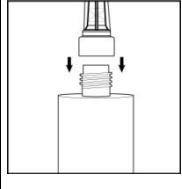
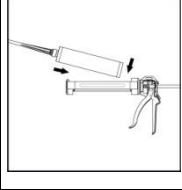
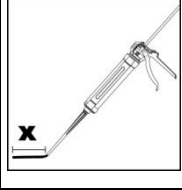
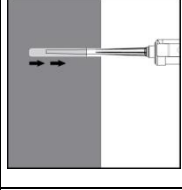
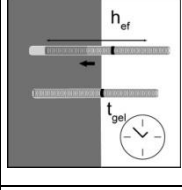
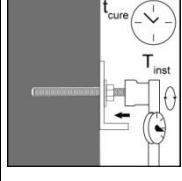
Annex B4
of European
Technical Assessment
ETA-19/0626

Table C1: Design method A, characteristic tension load values

POLY-GPG®/ POLY-GPG® PLUS with threaded rods			M8	M10	M12	M16	M20	M24
Steel failure								
Characteristic resistance, class 4.6 and 4.8	$N_{Rk,s}$	[kN]	15	23	34	63	98	141
Characteristic resistance, class 5.6 and 5.8	$N_{Rk,s}$	[kN]	18	29	42	78	122	176
Characteristic resistance, class 8.8	$N_{Rk,s}$	[kN]	29	46	67	125	196	282
Characteristic resistance, class 10.9	$N_{Rk,s}$	[kN]	38	60	87	163	255	367
Characteristic resistance, class 12.9	$N_{Rk,s}$	[kN]	44	70	103	190	299	431
Characteristic resistance, A2, A4 and HCR, Property class 50	$N_{Rk,s}$	[kN]	18	29	42	78	122	176
Characteristic resistance, A2, A4 and HCR, Property class 70	$N_{Rk,s}$	[kN]	26	41	59	110	171	247
Characteristic resistance, A4 and HCR, Property class 80	$N_{Rk,s}$	[kN]	29	46	67	126	196	282
Partial safety factor 4.6 and 5.6	$\gamma_{Ms,N}^{1)}$	[-]	2					
Partial safety factor 4.8, 5.8, 8.8, 10.9 and 12.9	$\gamma_{Ms,N}^{1)}$	[-]	1,5					
Partial safety factor A2, A4 and HCR class 70	$\gamma_{Ms,N}^{1)}$	[-]	1,87					
Partial safety factor A2, A4 and HCR class 80	$\gamma_{Ms,N}^{1)}$	[-]	1,60					
Combined Pull-out and Concrete cone failure ²⁾								
Diameter of threaded rod	d	[mm]	8	10	12	16	20	24
Characteristic bond resistance in non-cracked concrete C20/25 – dry or wet concrete								
Temperature range a ³⁾ : 40°C/24°C	$\tau_{Rk,ucr}$	[N/mm ²]	7	7	6.5	6.5	6	5.5
Partial safety factor – dry or wet concrete	γ_{inst}	[-]	1,2			1,4		
Characteristic bond resistance in non-cracked concrete C20/25 – flooded holes								
Temperature range a ³⁾ : 40°C/24°C	$\tau_{Rk,ucr}$	[N/mm ²]	7	7	6.5	6	5	4.5
Partial safety factor – flooded holes	γ_{inst}	[-]	1,2			1,4		
Increasing factor for $\tau_{Rk,ucr}$ in non-cracked concrete	ψ_c	C30/37	1,0					
		C40/50	1,0					
		C50/60	1,0					
Factor for determination of the concrete cone failure	$k_{ucr,N}$	[-]	11,0 (based on concrete cylinder strength f_{ck}) 10,1 (based on concrete strength $f_{ck,cube}$)					
Splitting failure²⁾								
Edge distance $c_{cr,sp}$ [mm] for	$h / h_{ef}^{4)} \geq 2,0$		1,0 h_{ef}					
	$2,0 > h / h_{ef}^{4)} > 1,3$		3 h_{ef} - 1 h					
	$h / h_{ef}^{4)} \leq 1,3$		1,7 h_{ef}					
Spacing	$s_{cr,sp}$	[mm]	2 $c_{cr,sp}$					

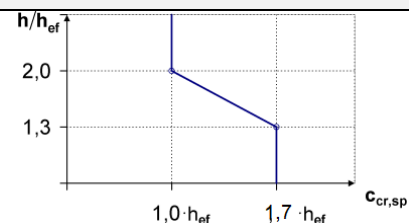

1) In absence of national regulations

2) Calculation of concrete and splitting, see annex B1

3) Explanations, see annex B1

4) h = concrete member thickness, h_{ef} = effective embedment depth**POLY-GPG®/ POLY-GPG® PLUS**

Performance for static and quasi-static loads: Resistances

Annex C1
of European
Technical Assessment
ETA-19/0626

Table C2: Displacements under tension load

POLY-GPG®/ POLY-GPG® PLUS with threaded rods			M8	M10	M12	M16	M20	M24
Temperature range a ⁵⁾ : 40°C / 24°C								
Displacement	δ_{N0}	[mm/(N/mm ²)]	0,03	0,04	0,04	0,04	0,09	0,30
Displacement	$\delta_{N\infty}$	[mm/(N/mm ²)]	-	-	0,15	-	-	-

⁵⁾ Explanation see annex B1

POLY-GPG®/ POLY-GPG® PLUS

Performance for static, quasi-static: Displacements

Annex C2
of European
Technical Assessment
ETA-19/0626

Table C3: Design method A, Characteristic shear load values

POLY-GPG®/ POLY-GPG® PLUS with threaded rods			M8	M10	M12	M16	M20	M24
Steel failure without lever arm								
Characteristic resistance, class 4.6 and 4.8	$V_{Rk,s}$ [kN]		7	12	17	31	49	70
Characteristic resistance, class 5.6 and 5.8	$V_{Rk,s}$ [kN]		9	15	21	39	61	88
Characteristic resistance, class 8.8	$V_{Rk,s}$ [kN]		15	23	34	63	98	141
Characteristic resistance, class 10.9	$V_{Rk,s}$ [kN]		19	30	43	81	127	183
Characteristic resistance, class 12.9	$V_{Rk,s}$ [kN]		22	35	51	95	149	215
Characteristic resistance, A2, A4 and HCR, Property class 50	$V_{Rk,s}$ [kN]		9	15	21	39	61	88
Characteristic resistance, A2, A4 and HCR, Property class 70	$V_{Rk,s}$ [kN]		13	20	30	55	86	124
Characteristic resistance, A4 and HCR, Property class 80	$V_{Rk,s}$ [kN]		15	23	34	63	98	141
Steel failure with lever arm								
Characteristic resistance, class 4.6 and 4.8	$M^0_{Rk,s}$ [Nm]		15	30	52	133	260	449
Characteristic resistance, class 5.6 and 5.8	$M^0_{Rk,s}$ [Nm]		19	37	65	166	324	560
Characteristic resistance, class 8.8	$M^0_{Rk,s}$ [Nm]		30	60	105	266	519	896
Characteristic resistance, class 10.9	$M^0_{Rk,s}$ [Nm]		37	75	131	333	649	1123
Characteristic resistance, class 12.9	$M^0_{Rk,s}$ [Nm]		45	90	157	400	779	1347
Characteristic resistance, A2, A4, HCR -50	$M^0_{Rk,s}$ [Nm]		19	37	65	166	324	560
Characteristic resistance, A2, A4, HCR -70	$M^0_{Rk,s}$ [Nm]		26	52	95	232	454	784
Characteristic resistance, A4, HCR - 80	$M^0_{Rk,s}$ [Nm]		30	59	105	266	519	896
Partial safety factor steel failure								
Steel, Property class 4.6 or 5.6	$\gamma_{Ms,V}^{1)}$ [-]		1,67					
Steel, Property class 4.8, 5.8 or 8.8	$\gamma_{Ms,V}^{1)}$ [-]		1,25					
Steel, Property class 10.9 or 12.9	$\gamma_{Ms,V}^{1)}$ [-]		1,50					
Stainless steel A2, A4 or HCR Property class 50	$\gamma_{Ms,V}^{1)}$ [-]		2,38					
Stainless steel A2, A4 or HCR Property class 70	$\gamma_{Ms,V}^{1)}$ [-]		1,56					
Stainless steel A4 or HCR Property class 80	$\gamma_{Ms,V}^{1)}$ [-]		1,33					
Concrete pryout failure								
Factor in equation (27) of EN 1992-4-5, 6.3.3	k_3 [-]		1,0		for $h_{ef} < 60\text{mm}$			
			2,0		for $h_{ef} \geq 60\text{mm}$			
Partial safety factor	$\gamma_{Mc}^{1)}$ [-]		1,5					
Concrete edge failure								
Partial safety factor	$\gamma_{Mc}^{1)}$ [-]		1,5					

1) In absence of national regulations

Table C4: Displacements under shear load

POLY-GPG®/ POLY-GPG® PLUS with threaded rods			M8	M10	M12	M16	M20	M24
Displacement	$\bar{\delta}_{V0}$	[mm/kN]	0,06	0,06	0,05	0,04	0,04	0,03
Displacement	$\bar{\delta}_{V\infty}$	[mm/kN]	0,09	0,08	0,08	0,06	0,06	0,05

POLY-GPG®/ POLY-GPG® PLUS

Performance for static, quasi-static loads: Resistances/Displacements

Annex C3
of European
Technical Assessment
ETA-19/0626

Table C5: Design method A, characteristic tension load values

POLY-GPG®/ POLY-GPG® PLUS with rebar			φ 8	φ 10	φ 12	φ 16	φ 20	φ 25
Steel failure								
Characteristic tension resistance	$N_{Rk,s}$	[kN]	$A_s \cdot f_{uk}^{1)}$					
Cross section area	A_s	[mm ²]	50	79	113	201	314	491
Partial safety factor	$\gamma_{Ms,N}^{2)}$	[-]	1,4					
Combined Pull-out and Concrete cone failure³⁾								
Diameter of rebar	d	[mm]	8	10	12	16	20	25
Characteristic bond resistance in non-cracked concrete C20/25 – dry or wet concrete								
Temperature range a ⁴⁾ : 40°C/24°C	$\tau_{Rk,ucr}$	[N/mm ²]	5.5	5.5	5.5	5	5	5
Partial safety factor – dry or wet concrete	$\gamma_{inst}^{2)}$	[-]	1,2			1,4		
Characteristic bond resistance in non-cracked concrete C20/25 – flooded holes								
Temperature range a ⁴⁾ : 40°C/24°C	$\tau_{Rk,ucr}$	[N/mm ²]	5.5	5.5	5.5	5	4.5	4
Partial safety factor – flooded holes	γ_{inst}	[-]	1,2			1,4		
Increasing factor for $\tau_{Rk,ucr}$ in non-cracked concrete	ψ_c	C30/37	1,0			1,1		
		C40/50	1,0	1,1				1,2
		C50/60	1,0	1,1	1,2		1,3	
Splitting failure³⁾								
Edge distance $c_{cr,sp}$ [mm] for	$h / h_{ef}^{5)} \geq 2,0$		1,0 h_{ef}					
	$2,0 > h / h_{ef}^{5)} > 1,3$		3 h_{ef} - 1 h					
	$h / h_{ef}^{5)} \leq 1,3$		1.7 h_{ef}					
Spacing	$s_{cr,sp}$	[mm]	2 $c_{cr,sp}$					

¹⁾ f_{uk} shall be taken from the specifications of reinforcing bars

²⁾ in absence of national regulation

³⁾ Calculation of concrete and splitting, see annex B1

⁴⁾ Explanations, see annex B1

⁵⁾ h = concrete member thickness, h_{ef} = effective embedment depth

Table C6: Displacements under tension load

POLY-GPG®/ POLY-GPG® PLUS with rebar			φ 8	φ 10	φ 12	φ 16	φ 20	φ 25
Temperature range a ⁴⁾ : 40°C / 24°C								
Displacement	δ_{N0}	[mm/(N/mm ²)]	0,03	0,03	0,04	0,07	0,07	0,10
Displacement	$\delta_{N\infty}$	[mm/(N/mm ²)]	-	-	0,15	-	-	-

POLY-GPG®/ POLY-GPG® PLUS

Performance for static and quasi-static loads: Resistances/Displacements

Annex C4
of European
Technical Assessment
ETA-19/0626

Table C7: Design method A, Characteristic shear load values

POLY-GPG®/ POLY-GPG® PLUS with rebar			φ 8	φ 10	φ 12	φ 16	φ 20	φ 25
Steel failure without lever arm								
Characteristic shear resistance	$V_{Rk,s}$	[kN]	$0,50 \cdot A_s \cdot f_{uk}^{1)}$					
Cross section area	A_s	[mm ²]	50	79	113	201	314	491
Partial safety factor	$\gamma_{Ms,N}^{2)}$	[-]	1,5					
Steel failure with lever arm								
Characteristic bending moment	$M^0_{Rk,s}$	[Nm]	$1,2 \cdot W_{el} \cdot f_{uk}^{1)}$					
Elastic section modulus	W_{el}	[Nm]	50	98	170	402	785	1534
Partial safety factor	$\gamma_{Ms,N}^{2)}$	[-]	1,5					
Concrete pryout failure								
Factor	k_8	[-]	1,0		for $h_{ef} < 60\text{mm}$			
			2,0		for $h_{ef} \geq 60\text{mm}$			
Partial safety factor	γ_{Mc}	[-]	1,5					
Concrete edge failure								
Partial safety factor	$\gamma_{Mc}^{1)}$	[-]	1,5					

¹⁾ f_{uk} shall be taken from the specifications of reinforcing bars

²⁾ In absence of national regulations

Table C8: Displacements under shear load

POLY-GPG®/ POLY-GPG® PLUS with rebar			φ 8	φ 10	φ 12	φ 16	φ 20	φ 25
Displacement	δ_{V0}	[mm/kN]	0,05	0,05	0,05	0,04	0,04	0,03
Displacement	$\delta_{V\infty}$	[mm/kN]	0,08	0,08	0,07	0,06	0,05	0,05

POLY-GPG®/ POLY-GPG® PLUS

Performance for static and quasi-static loads: Resistances/Displacements

Annex C5
of European
Technical Assessment
ETA-19/0626

Table C9: Resistance to fire

ESSENTIAL CHARACTERISTICS	PERFORMANCE
Resistance to fire	NPA

Table C10: Reaction to fire

ESSENTIAL CHARACTERISTICS	PERFORMANCE
Reaction to fire	In the final application, the thickness of the mortar layer is about 1 to 2 mm and most of the mortar is material classified class A1 according to EC Decision 96/603/EC. Therefore, it may be assumed that the bonding material (synthetic mortar or a mixture of synthetic mortar and cementitious mortar) in connection with the metal anchor in the end use application do not contribute to fire growth or to the fully developed fire and they have no influence to the smoke hazard.

POLY-GPG®/ POLY-GPG® PLUS

Performance for exposure to fire

Annex C6
of European
Technical Assessment
ETA-19/0626